



HKV FLUSH ANCHOR

Technical Datasheet

Update: Dec-17





HKV Flush anchors

Economical manual set flush anchor

Anchor version



HKV
(M6-M16)

Benefits

- Simple and well proven
- Approved, tested and confirmed by every day jobsite experience
- Reliable setting thanks to simple visual check
- Versatile
- For medium-duty fastening with bolts or threaded rods
- Available in various materials and sizes for maximized coverage of possible applications

Base material



Concrete
(non-cracked)

Basic loading data (for a single anchor)

All data in this section applies to:

- Correct setting (See setting instruction)
- No edge distance and spacing influence
- Concrete as specified in the table
- Minimum base material thickness
- Concrete C 20/25, $f_{ck,cube} = 25 \text{ N/mm}^2$
- Screw or rod with steel grade 5.8 (carbon steel) and / or A4-70 (stainless steel)

Effective anchorage depth

Anchor size	Metric	M6	M8	M10	M10	M12	M16
	Imperial	1/4	5/16	3/8	3/8	1/2	-
Eff. anchorage depth range	h_{ef} [mm]	25	30	30	40	50	65

Mean ultimate resistance

Anchor size	Metric	M6	M8	M10	M10	M12	M16
	Imperial	1/4	5/16	3/8	3/8	1/2	-
Tension $N_{Ru,m}$	HKV [kN]	5,6	7,8	7,8	12,1	16,9	35,3
Shear $V_{Ru,m}$	HKV [kN]	5,5	9,4	11,0	11,0	20,1	37,1

Characteristic resistance

Anchor size	Metric	M6	M8	M10	M10	M12	M16
	Imperial	1/4	5/16	3/8	3/8	1/2	-
Tension N_{Rk}	HKV [kN]	4,2	5,9	5,9	9,1	12,7	26,5
Shear V_{Rk}	HKV [kN]	5,0	8,6	10,0	11,0	18,3	33,8

Design resistance

Anchor size	Metric		M6	M8	M10	M10	M12	M16
	Imperial		1/4	5/16	3/8	3/8	1/2	-
Tension N_{Rd}	HKV	[kN]	2,8	3,9	3,9	6,1	8,5	17,6
Shear V_{Rd}	HKV	[kN]	5,0	8,6	8,0	8,0	14,6	27,0

Recommended loads ^{a)}

Anchor size	Metric		M6	M8	M10	M10	M12	M16
	Imperial		1/4	5/16	3/8	3/8	1/2	-
Tension N_{Rec}	HKV	[kN]	2,0	2,8	2,8	4,3	6,0	12,6
Shear V_{Rec}	HKV	[kN]	2,9	4,9	5,7	5,7	10,5	19,3

a) With overall partial safety factor for action $\gamma = 1,4$. The partial safety factors for action depend on the type of loading and shall be taken from national regulations. According to ETAG 001, the partial safety factor is $\gamma_G = 1,35$ for permanent actions and $\gamma_Q = 1,5$ for variable actions.

Materials

Mechanical properties

Anchor size	Metric		M6	M8	M10	M10	M12	M16
	Imperial		1/4	5/16	3/8	3/8	1/2	-
Nominal tensile strength	f_{uk}	[N/mm ²]	570	570	570	570	570	640
Yield strength	f_{yk}	[N/mm ²]	460	460	460	460	460	510
Stressed cross-section	A_s	[mm ²]	20,7	26,7	32,7	32,7	60,1	105
			17,3	27,46	39,9	39,9	70,6	-
Moment of resistance	W	[mm ³]	32,3	54,6	82,9	82,9	184	431
			28,2	55,8	97,4	97,4	229,8	-
Char. bending resistance for rod or bolt with 5.8 steel grade	$M^{0}_{Rk,s}$	[Nm]	7,6	18,7	37,4	37,4	65,5	167
			10,4	16,5	23,9	24,5	42,4	-

Material quality

Part	Material
Anchor body	Steel Fe/Zn5 galvanized to min. 5 μ m
Expansion plug	Steel material

Anchor dimension

Anchor size	Metric		M6	M8	M10	M10	M12	M16
	Imperial		1/4	5/16	3/8	3/8	1/2	-
Effective anchorage depth	h_{ef}	[mm]	25	30	30	40	50	65
Anchor diameter	d_1	[mm]	7,9	9,95	11,8	11,95	14,9	19,75
				9,9	11,9		15,85	-
Diameter of cone bolt	d_2	[mm]	5,1	6,5	8,2	8,2	10,3	13,8
				6,35		7,86	10,2	-
Length of expansion sleeve	l_1	[mm]	10	12	12	16	20	29
						16,2		-



Anchor body

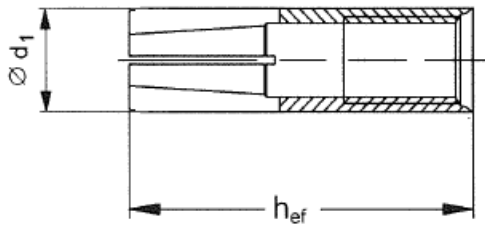

Expansion plugs

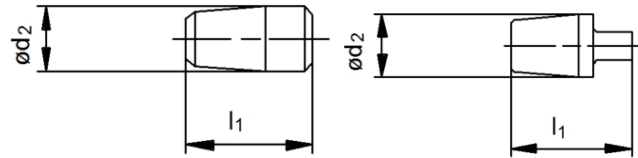

Setting information

Setting details

Anchor size	Metric	M6	M8	M10	M10	M12	M16
	Imperial	1/4	5/16	3/8	3/8	1/2	-
Effective anchorage depth	h_{ef} [mm]	25	30	30	40	50	65
Nominal diameter of drill bit	d_0 [mm]	8	10	12	12	15 16	20
Cutting diameter of drill bit	$d_{cut} \leq$ [mm]	8,45	10,5	13 12,5	12,5	15,5 16,5	20,5
Depth of drill hole	$h_1 \geq$ [mm]	27	33	33	43	54	70
Diameter of clearance hole in the fixture	$d_f \leq$ [mm]	7	9	12	12	14	18
Torque moment	T_{inst} [Nm]	4	8	15	15	35	60
Screwing depth	$l_{s,min}$ [mm]	6	8	10	10	12	16
	$l_{s,max}$ mm]	10	12	10,5	15,5	20,0	25,5

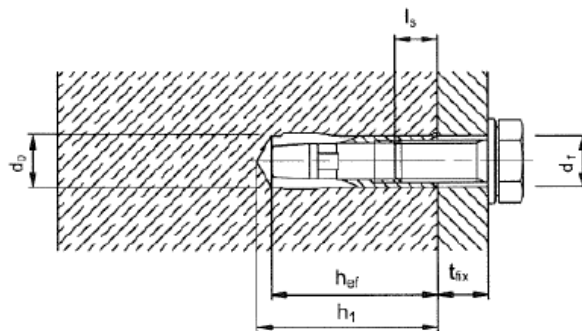

Setting parameters

Anchor size	Metric	M6	M8	M10	M10	M12	M16
	Imperial	1/4	5/16	3/8	3/8	1/2	-
Minimum base material thickness	$h_{min} \geq$ [mm]	100	100	100	100	100	130
Minimum spacing	$s_{min} \geq$ [mm]	200	200	200	200	200	260
Minimum edge distance	$c_{min} \geq$ [mm]	150	150	150	150	150	195

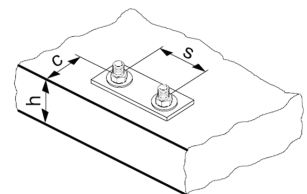

Installation equipment

Anchor size	Metric	M6	M8	M10	M10	M12	M16
	Imperial	1/4	5/16	3/8	3/8	1/2	-
Rotary hammer for setting	TE 1 – TE 30					TE 16 – TE 50	
	TE 1 – TE 30						
Machine setting tool	HSD-M	6x25/30	8x25/30	10x25/30	10x40	12x50	16x65
		1/4x25	5/16x30	3/8x30	3/8x40	1/2x50	-
Hand setting tool	HSD-G	6x25/30	8x25/30	10x25/30	10x40	12x50	16x65
		1/4x25	5/16x30	3/8x30	3/8x40	1/2x50	-
Other tools	hammer, torque wrench, blow out pump						

Setting instruction

*For detailed information on installation see instruction for use given with the package of the product.

Setting instruction	
<p>1. Drilling</p>	<p>2. Cleaning</p>
<p>3. Inserting the anchor</p>	<p>4. Setting tools</p>
<p>5. Inserting the tools</p>	<p>6. Inserting the tools</p>
<p>7. Attaching the belonging washer</p>	<p>8.</p>